

QUAD COMPARATOR INTERFACE CIRCUIT

- MINIMUM HYSTERESIS VOLTAGE AT EACH INPUT : 0.3V
- OUTPUT CURRENT : 15 mA
- LARGE SUPPLY VOLTAGE RANGE : + 10V to + 35V
- INTERNAL THERMAL PROTECTION
- INPUT AND OUTPUT CLAMPING PROTECTION DIODES.

DESCRIPTION

The ESM1602B is a quadruple comparator intended to provide an interface between signal processing and transmitting lines in very noisy industrial surroundings.

Output of each comparator, used as line driver, supplies a constant current (PNP output stage) and is specially well protected against powerful overvoltages. The open collector output circuit allows the connection of several comparators to a single transmitting line.

The ESM1602B can operate as receiver on a line transmitting noisy high-voltage signals. Hysteresis effect, internally implemented on inputs of each comparator provides an excellent noise immunity. In addition, each input is also protected against overvoltages.

PIN CONNECTIONS (top view)

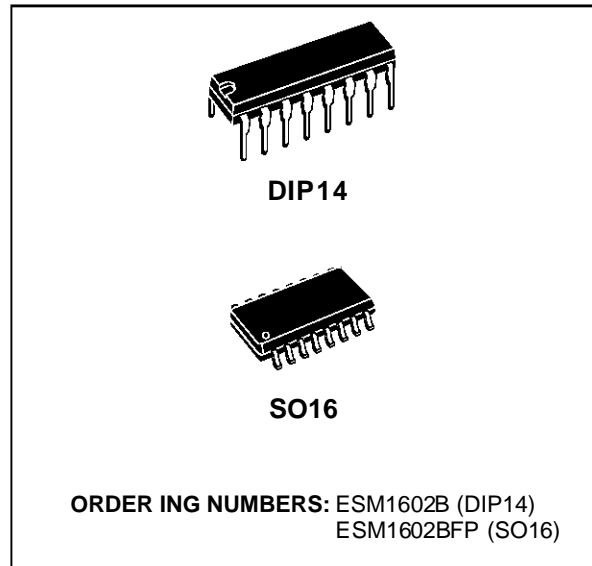
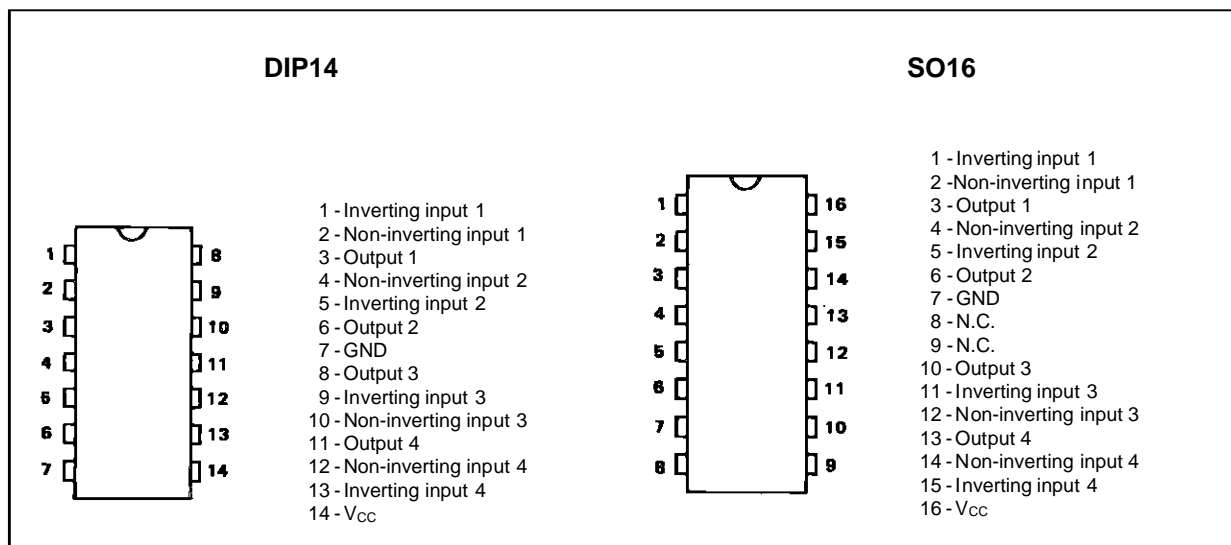

The ESM1602B can operate in a wide supply voltage range (standard operational amplifier ± 15 V supply or single + 12 V or + 24 V supplies used in industrial electronic sets).

Moreover, internal thermal protection circuitry cuts out the output current of the four comparators when power dissipation becomes excessive.

SCHEMATIC DIAGRAM

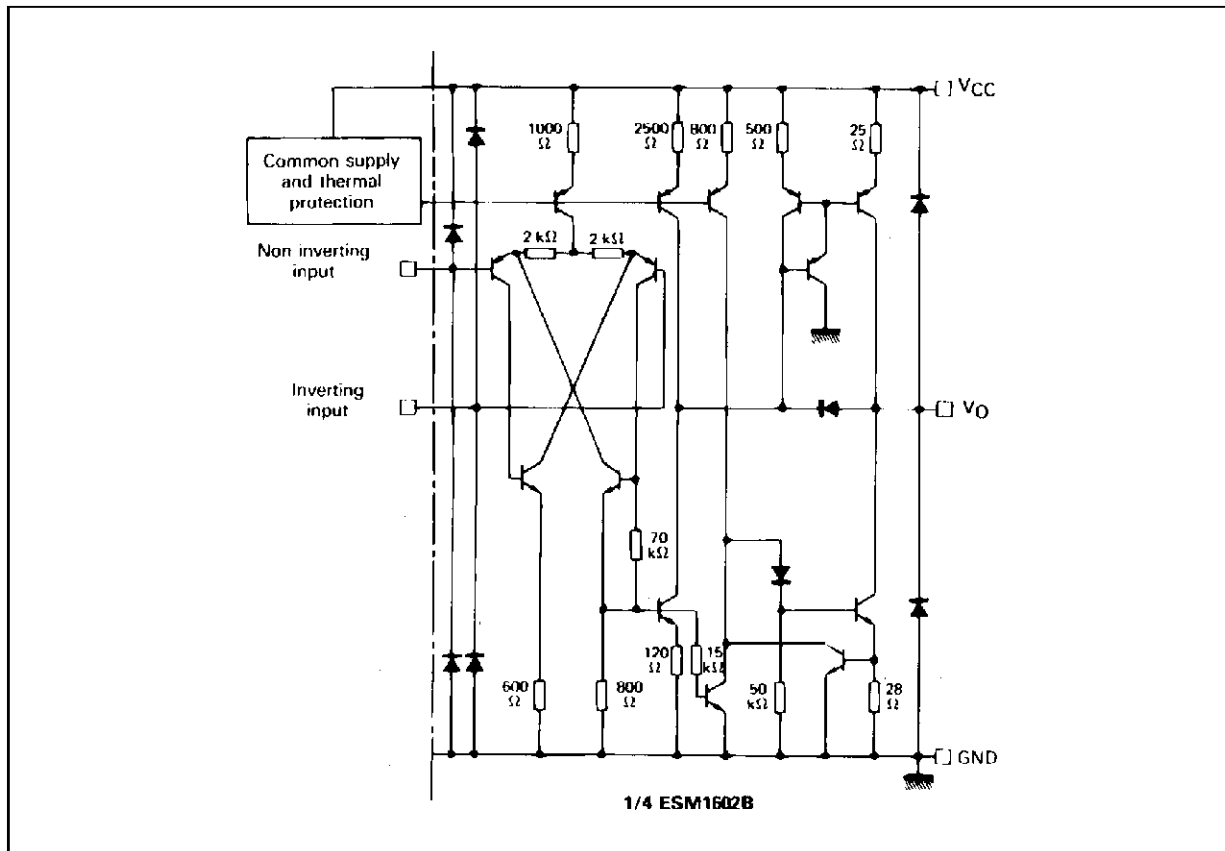

ABSOLUTE MAXIMUM RATINGS

Symbol	Parameter	Value	Unit
V _{CC}	Supply Voltage	45	V
V _{ID}	Differential Input Voltage	45	V
V _I	Input Voltage	-0.7 to +45	V
I _{O (max)}	Output Current	Internally Limited	mA
P _{tot}	Power Dissipation	Internally Limited	W
T _{op}	Operating Ambient Temperature Range	-25 to +85	°C
T _{stg}	Storage Temperature Range	-40 to +150	°C

ELECTRICAL CHARACTERISTICS
 $V_{CC} = +35V, -25^{\circ}C \leq T_{amb} \leq +85^{\circ}C$ (unless otherwise specified)

Symbol	Parameter	Min.	Typ.	Max.	Typ.	Fig.
V_{I+} V_{I-}	Input Voltage Range - Note 1 Non-inverting Input Inverting Input	0 2		33 33	V V	
V_C	Input Control Voltage ($2V < V_{CM} < 33V$) - Note 2	150		500	mV	8
I_{IB}	Input Bias Current - Note 3		1	5	μA	
I_{SC}	Short-circuit Output Current $V_{CC} = +10$ to $+35$ V	6		25	mA	9
$V_{CC}-V_O$	Output Saturation Voltage (high level) - ($I_O = -10$ mA)		1	1.5	V	11
V_O	Output Saturation Voltage (high level) - ($I_O = -10$ mA)		1	1.6	V	12
I_{CC}	Supply Current $R_L = \infty$ for the 4 Comparators R_L Common for the 4 Comparators		4 10	6 13	mA mA	13,14
S_{VO}	Output Slew-rate ($R_L = 3k\Omega, T_{amb} = +25^{\circ}C$)	1			V/ μs	
V_F	Input Protective Diode Forward Voltage ($I = 20$ mA, $T_{amb} = +25^{\circ}C$)			1.5	V	
-	Energy of Pulses against which Circuit Output is Protected ($T_{amb} = +25^{\circ}C$) - Note 4			20	mJ	
-	Pulsed Current Applied to Protective Output Diodes ($T_{amb} = +25^{\circ}C$) - Note 5		0.4		A	15

- Notes :**
- When negative input is biased between 0 and 2 volts output is always low.
 - Comparator hysteresis voltage on positive input on the one hand and negative input on the other hand equals sum of input control voltages $V_{C1} + V_{C2}$ or $V_{C3} + V_{C4}$.
 - Input current flows out of the circuit owing to PNP input stage. This current is constant and independent of output level. So no load change is transmitted to inputs.
 - By definition, a circuit is immunized against powerful signals when no durable characteristic change occurs after the application of these signals and when the circuit has not been destroyed.
In industrial surroundings, parasitic signals contain usually high voltage (over 200 V) AC harmonics having variable impedance of 500 Ω to 10k Ω .
The power dissipation of these signals is divided between clamping diodes and the V_{CC} . Simulation is used to determine the maximum energy level. The injected current value cannot in any case exceed 3A.
 - Output protective diodes are tested individually by means of positive and negative discharge voltages of a capacitor. The negative discharge control occurs through a single diode. During positive discharge, due to the properties of integration, a grounded collector PNP transistor appears in parallel with the clamping diode connected to V_{CC} . A part of the current flows through this transistor, V_{CE} being greater than V_{CC} . If T is the total discharge duration, energy dissipated in the circuit is :

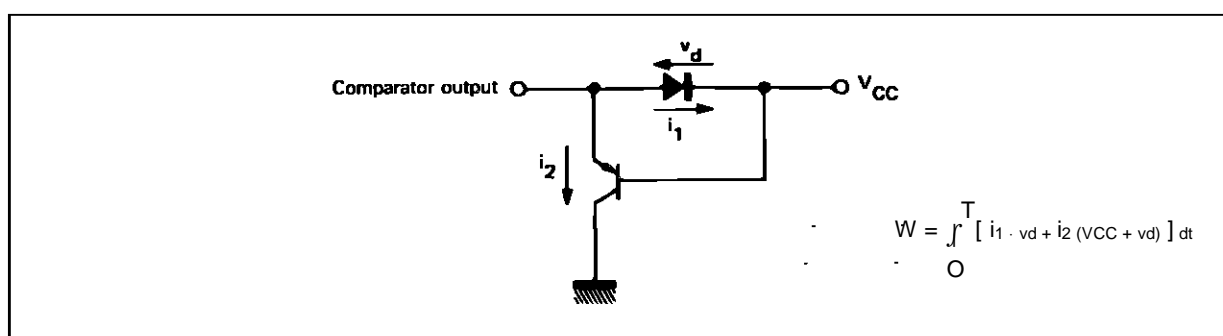

For a certain injected current, the lower the current i_2 , that is to say the lower the PNP current gain the smaller the energy is dissipated in the circuit. Topology and technological processes have been chosen to shorten this current gain.

Figure 1: Input Bias Current

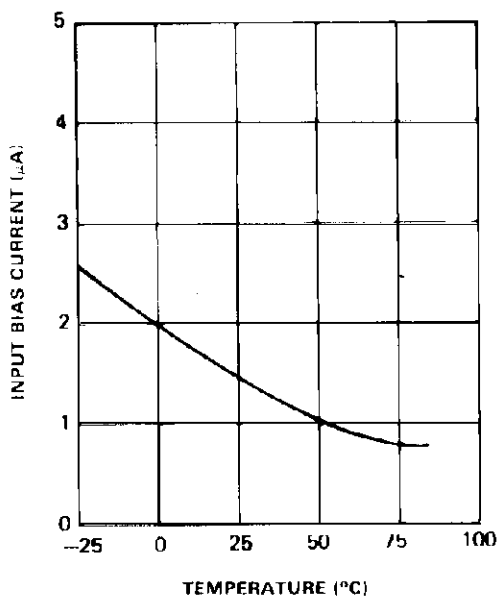

Figure 2: Output Saturation Voltage

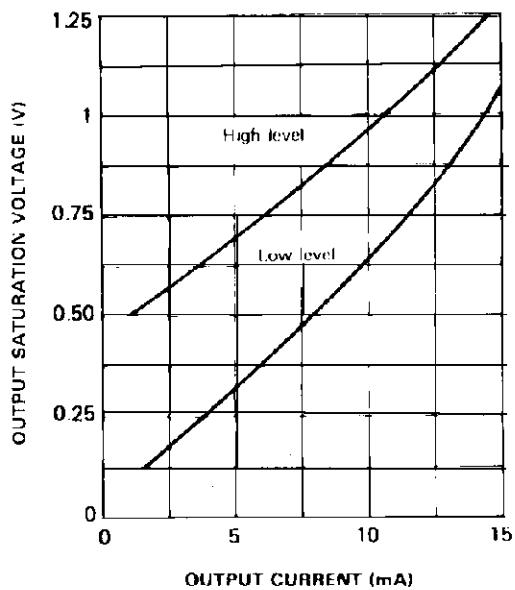

Figure 3: Output Saturation Voltage

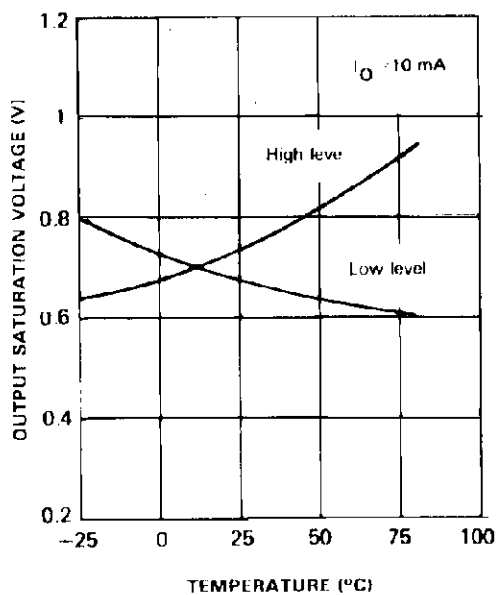
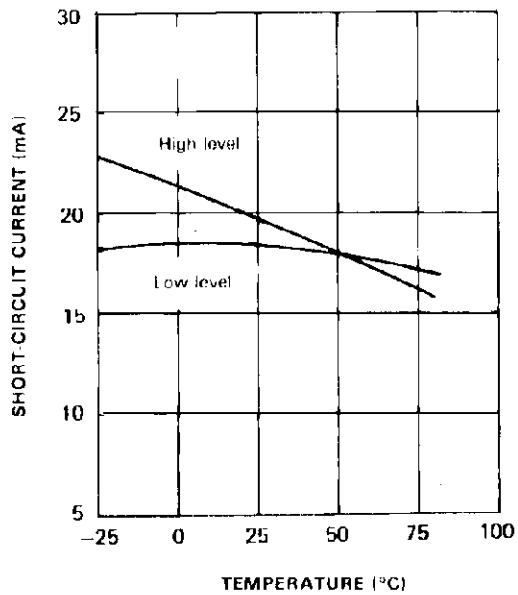

Figure 4: Short Circuit Current



TYPICAL APPLICATIONS

Figure 5 : Conversion of DTL, TTL, MOS Signals on a Transmitting Line.

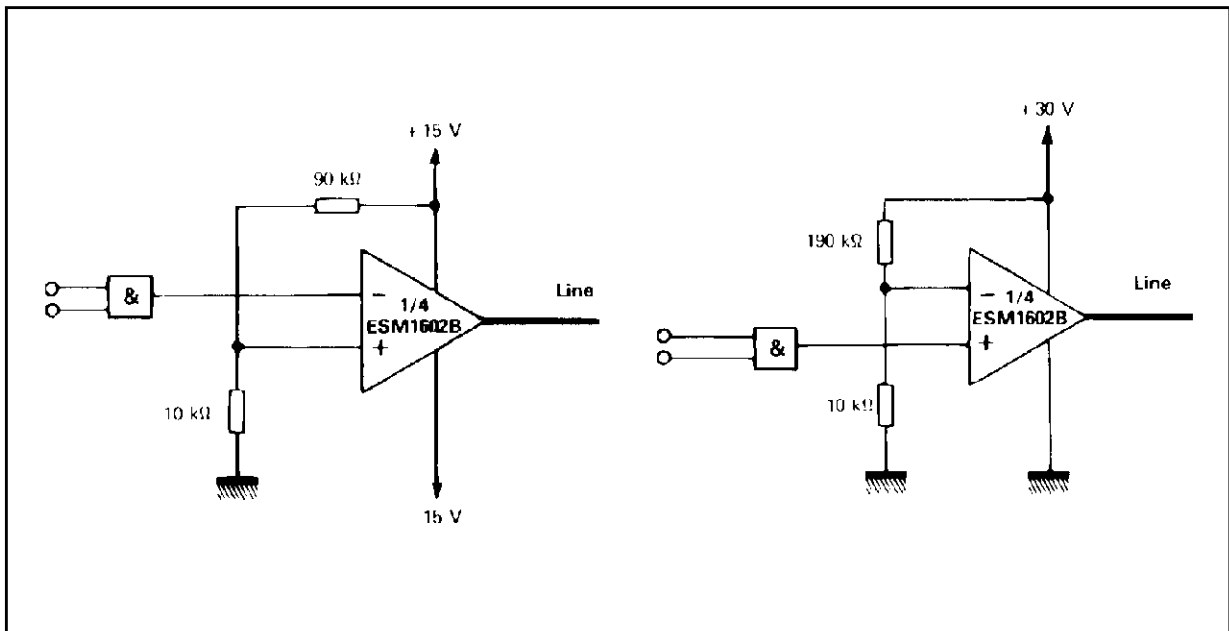

Figure 6 : Reception of Highly Noisy Signals.

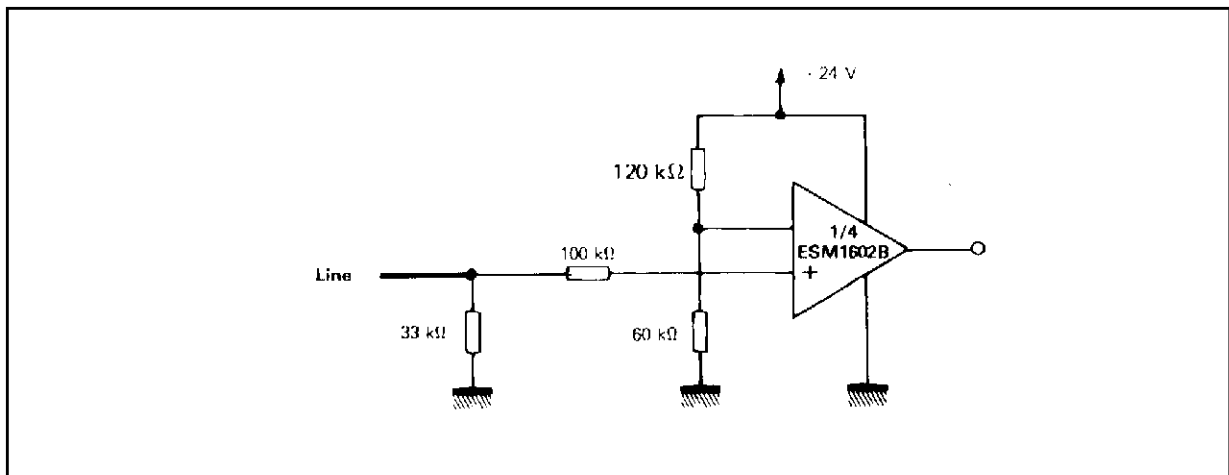
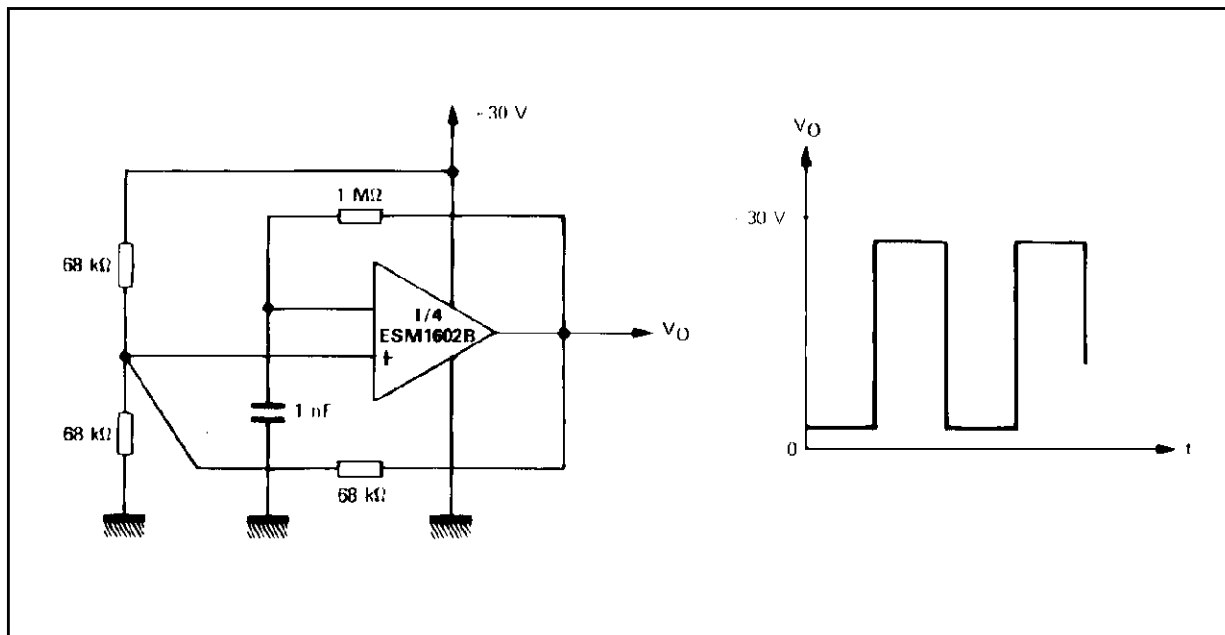

Figure 7.



TEST CIRCUITS

Figure 8.

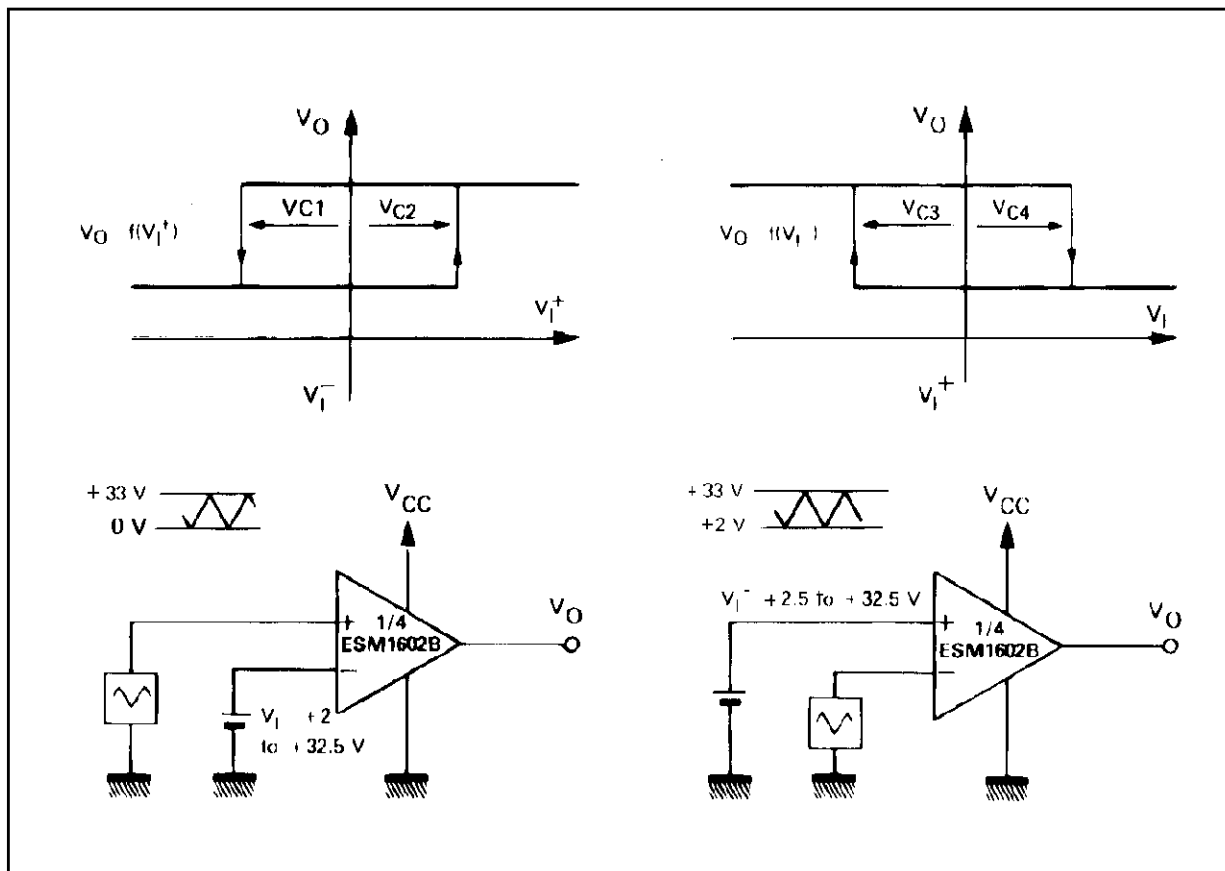

Figure 9.

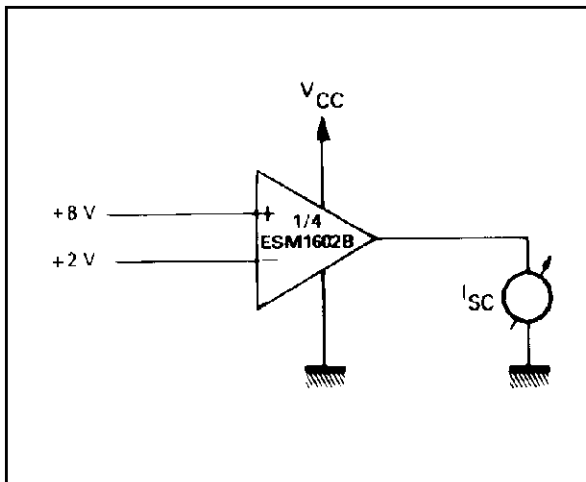

Figure 10.

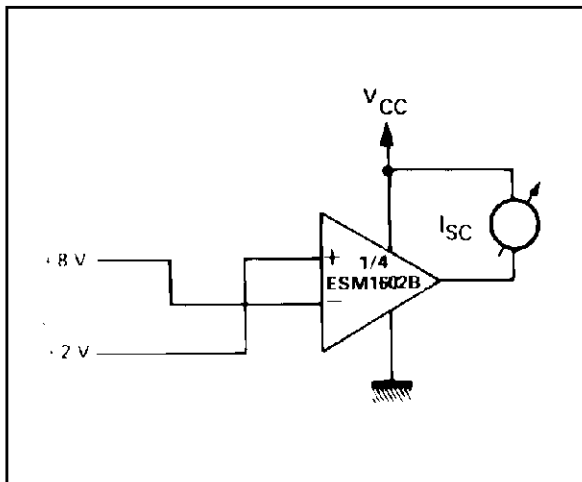

Figure 11.

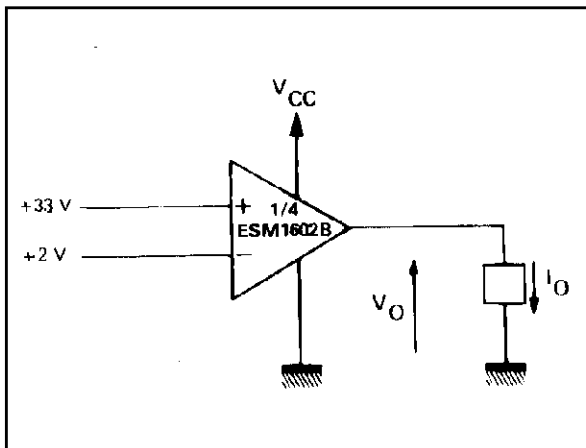

Figure 12.

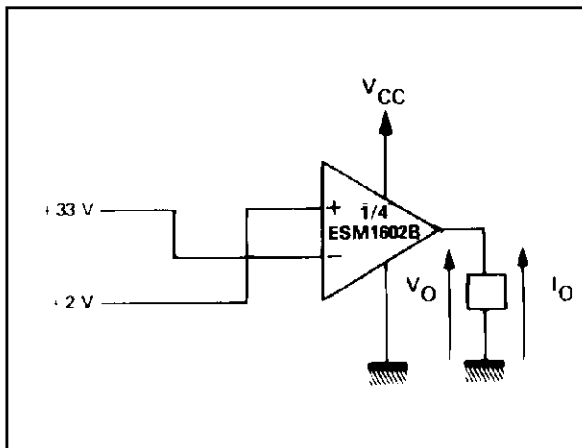

Figure 13.

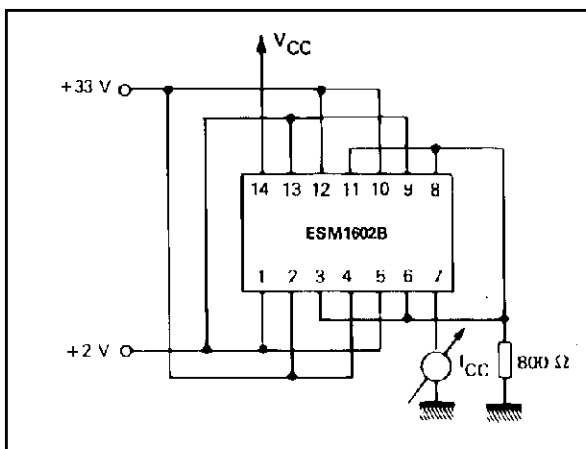

Figure 14.

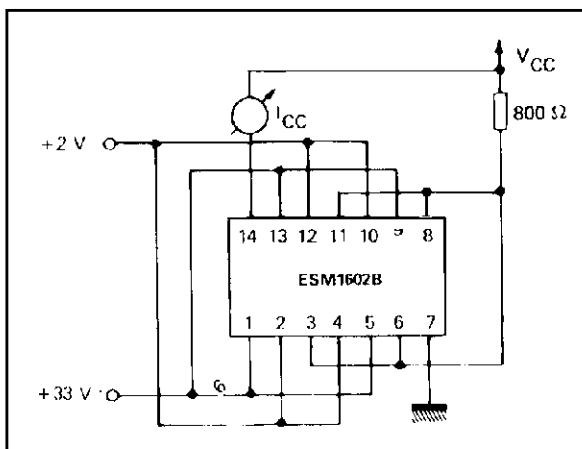

Figure 15.

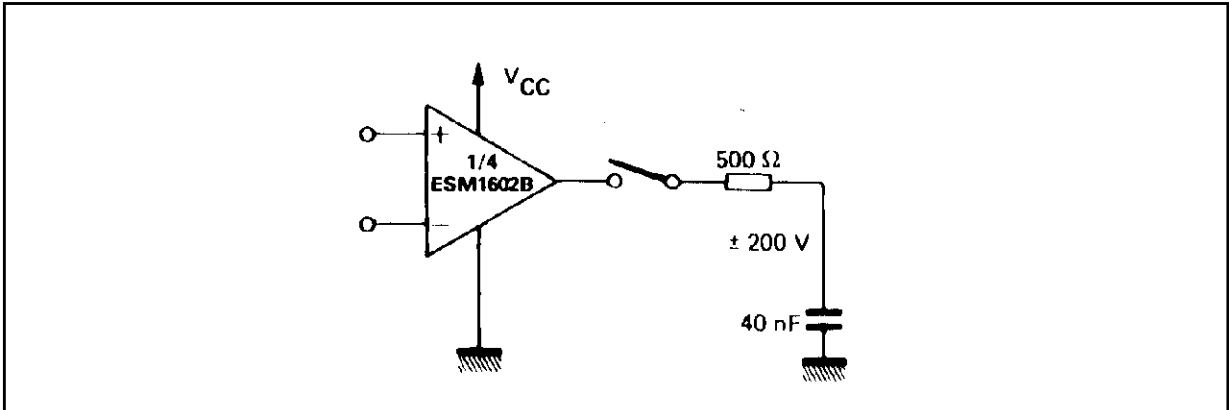
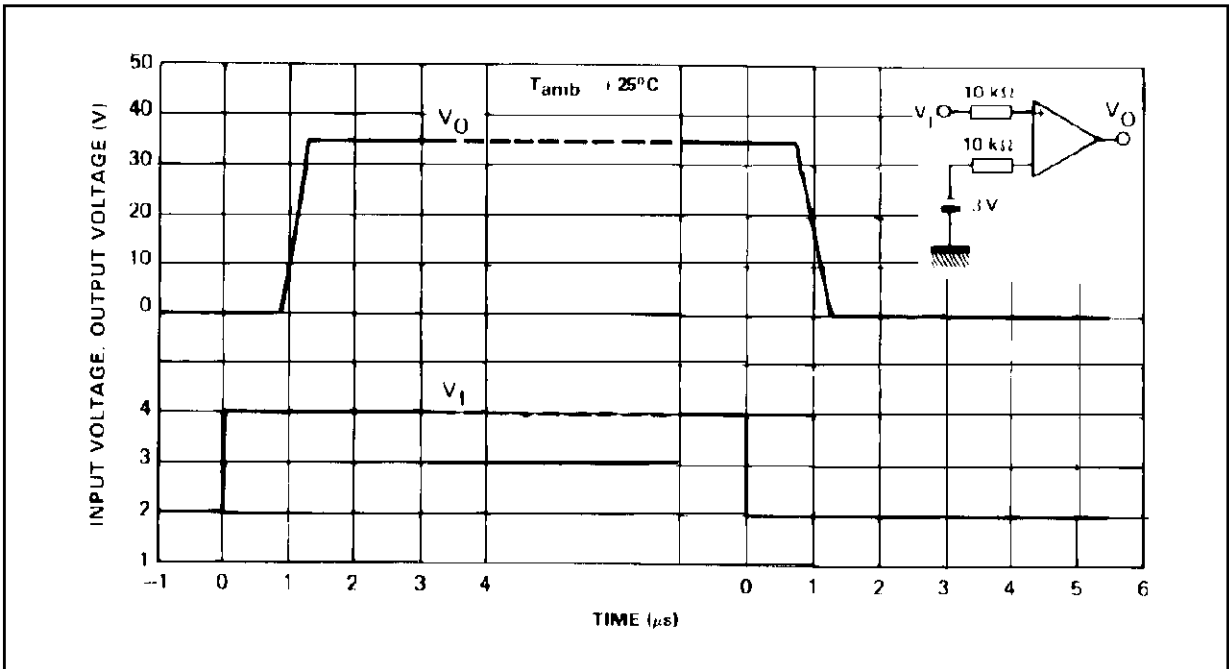

Figure 16: Response Time.



DIP16 PACKAGE MECHANICAL DATA

Dimensions	Millimeters			Inches		
	Min.	Typ.	Max.	Min.	Typ.	Max.
a1	0.51			0.020		
B	1.39		1.65	0.055		0.065
b		0.5			0.020	
b1		0.25			0.010	
D			20			0.787
E		8.5			0.335	
e		2.54			0.100	
e3		15.24			0.600	
F			7.1			0.280
i			5.1			0.201
L		3.3			0.130	
Z	1.27		2.54	0.050		0.100

DIP14.TBL

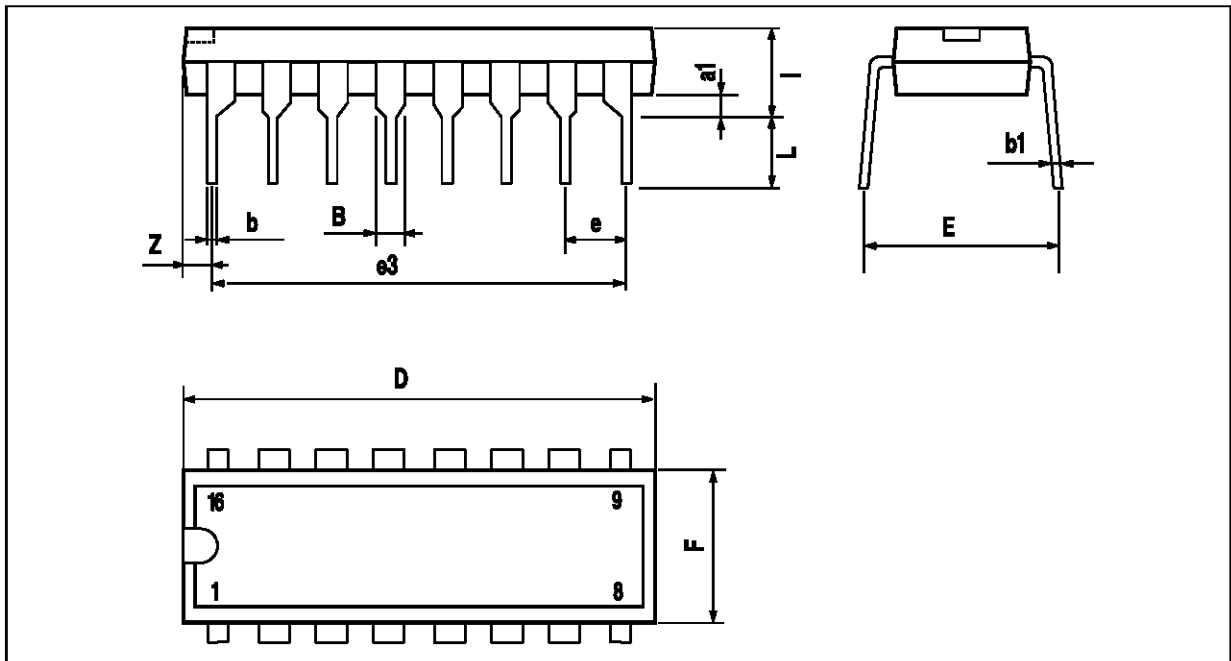

S016 PACKAGE MECHANICAL DATA

Dimensions	Millimeters			Inches		
	Min.	Typ.	Max.	Min.	Typ.	Max.
A			1.75			0.069
a1	0.1		0.2	0.004		0.008
a2			1.6			0.063
b	0.35		0.46	0.014		0.018
b1	0.19		0.25	0.007		0.010
C		0.5			0.020	
c1	45° (typ.)					
D	9.8		10	0.386		0.394
E	5.8		6.2	0.228		0.244
e		1.27			0.050	
e3		8.89			0.350	
F	3.8		4.0	0.150		0.157
G	4.6		5.3	0.181		0.209
L	0.5		1.27	0.020		0.050
M			0.62			0.024
S	8° (max.)					

S016.TBL

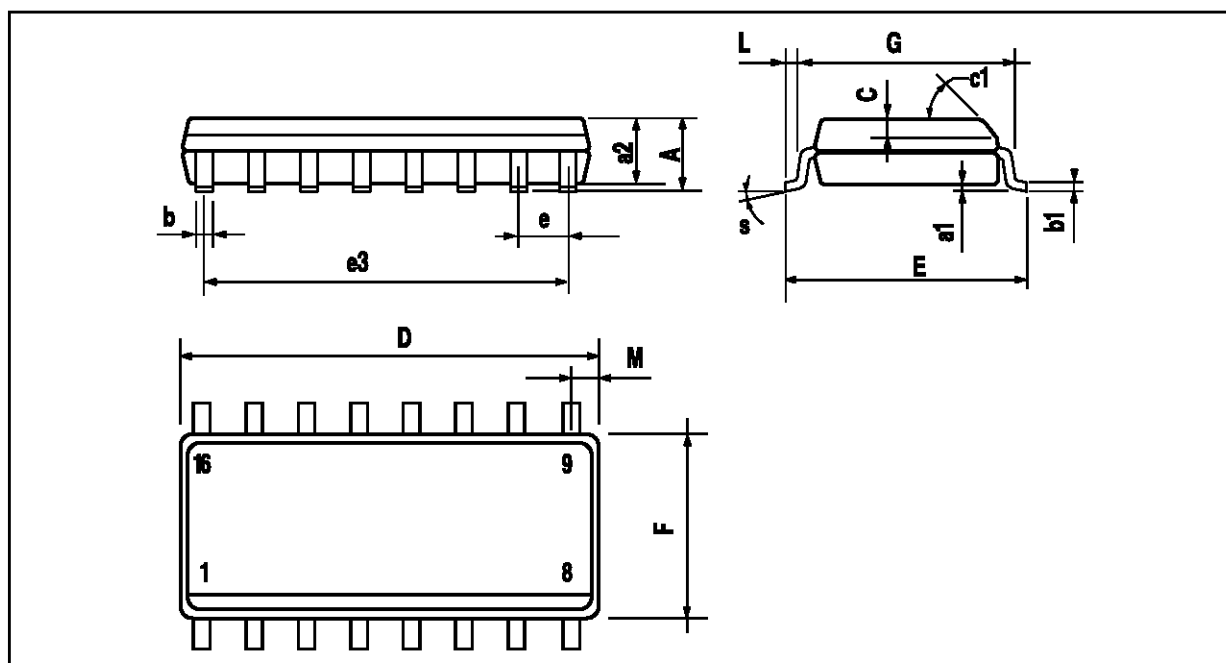

Information furnished is believed to be accurate and reliable. However, SGS-THOMSON Microelectronics assumes no responsibility for the consequences of use of such information nor for any infringement of patents or other rights of third parties which may result from its use. No license is granted by implication or otherwise under any patent or patent rights of SGS-THOMSON Microelectronics. Specifications mentioned in this publication are subject to change without notice. This publication supersedes and replaces all information previously supplied. SGS-THOMSON Microelectronics products are not authorized for use as critical components in life support devices or systems without express written approval of SGS-THOMSON Microelectronics.

© 1995 SGS-THOMSON Microelectronics All Rights Reserved

SGS-THOMSON Microelectronics GROUP OF COMPANIES

Australia - Brazil - France - Germany - Hong Kong - Italy - Japan - Korea - Malaysia - Malta - Morocco - The Netherlands - Singapore - Spain - Sweden - Switzerland - Taiwan - Thailand - United Kingdom - U.S.A.